



ILT-1600 InLine Turning Machine

ADVANTAGES

- Induction hardened chrome guide bars
- Precision linear guide bearings
- Twin lead-screws for balanced feeding
- Capable of doing stub shafts or inline turning
- Variable speed feed control
- Variable and reversible rotation rates
- Two position feed motor, rapid traverse clutch, ability to cut threads
- X/Y adjustable mounting
- Custom sizes for unique applications
- High quality alloys and fittings, 20-ft hoses
- Custom split frame available on request



APPLICATIONS

- Bearing Journals
- Shafts
- Pulp & Paper
- Manufacturing Industries
- Agriculture
- Aerospace
- Construction
- Mining
- Oil & Gas
- Hydro Electric

PRODUCT DESCRIPTION

SPR's ILT-1600 InLine Turning Lathe is the perfect tool for on-site resurfacing of large shafts, stub shafts, and bearing journals/seats, requiring little disassembly or costly relocation of equipment. These machines run on precision linear guide bearings and are driven by two lead screws for balanced feeding. Both feed and rotation are hydraulically driven with continuous speed control and are independently adjustable while in use.

The ILT-1600 is offered in both standard and custom sizes for unique applications. It is designed for shaft servicing covering diameters from 8.0 in to 16.0 in (203.20 mm to 406.40 mm). Custom split frames are available upon request.

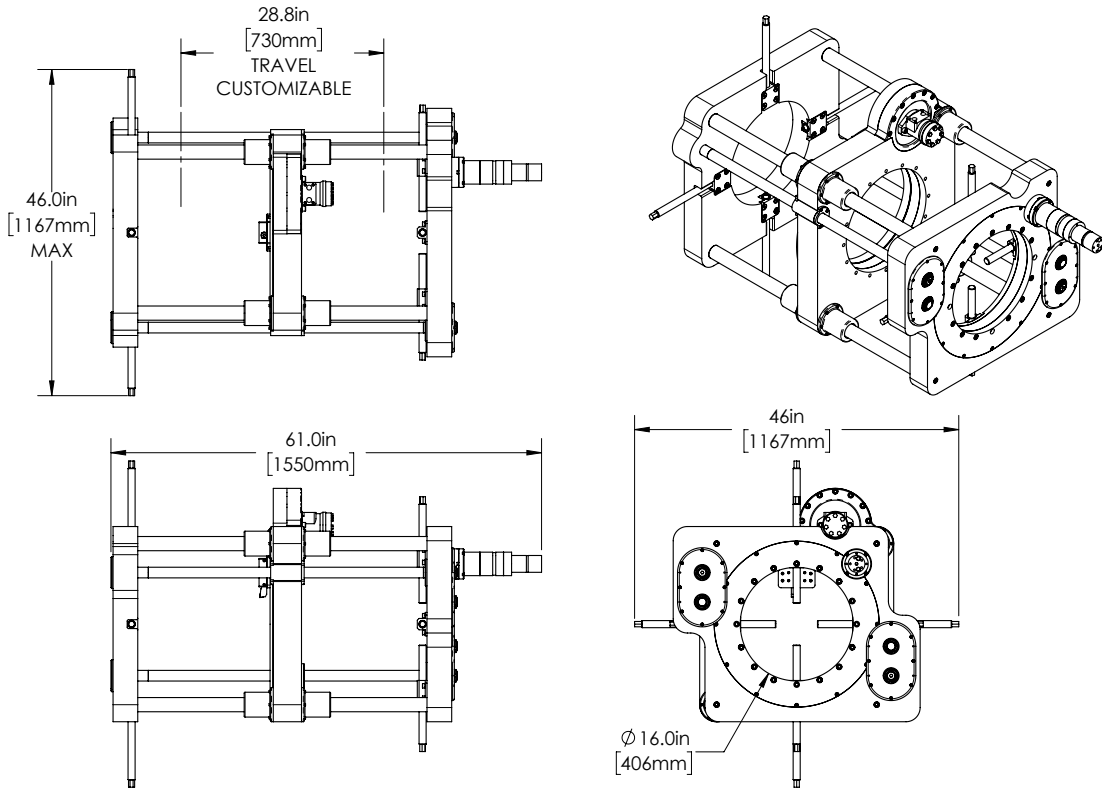

SPECIFICATIONS

Machining Performance Range		ILT-1600
ID Mounting Range:	Min Diameter	8.0 in (203.20 mm)
	Max Diameter	16.0 in (406.40 mm)
Drive System		
Max Feed		1.80 in (45.75 mm) / min
Max RPM		280 RPM
Measurements		
Machine Weight		1010 lbs
Shipping Weight		1450 lbs
Dimensions		
Machine (LxWxH)		60 in (1524 mm) x 37.8 in (960 mm) x 37.8 in (960 mm)
Crate/Shipping (LxWxH)		71 in (1803.4 mm) x 44 in (1117.6 mm) x 41 in (1041.1 mm)



833.447.3777



info@sprtool.com



sprtool.com