



# Hunger VD2

## Valve Seat Refacing Tool

for 30° and 45° valve seats from 30 to 90mm diameter

**Capacity:**

Valve seat diameter range 30 - 90mm  
Seat angle 30° and 45°

**Feed motions:**

Rotary motion manual  
Transverse feed 0,05 mm/rev

**Dimensions:**

Length 175mm  
Width 70mm  
Height 260mm

**Weight:**

Net weight 2,5kg

## Hunger valve seat refacing, the superior alternative to grinding and form cutting.

### Working principle:

The valve seat is refaced in a lathe-type facing action.

While the single point cutting tool is rotated in a circle around the valve seat, a feed gear ensures a continuous outward transverse feed motion under the proper seat angle.

This angle is defined by an inclined slide-way in the gear head.

A pilot inserted in the valve guide aligns the VD2 in centerline with the valve guide.

A swiveling guide arm is provided below the crank handle for additional support.

To eliminate run out when the VD2 is rotated around the pilot, the swiveling guide arm is locked in place either by a steady rest which is mounted on the cylinder head or by means of the Hunger K2000 cylinder head stand.

### Handling:

Operation is straightforward.

First, insert the pilot into the valve guide.

Then place the VD2 over the pilot and lock swiveling guide arm in place.

Lower the VD2 until the cutting tool is just in contact with the valve seat.

Turn rapid tool traverse to position the cutting tool in front of the inner edge of the valve seat.

Turn micrometer downfeed to set the desired depth of cut.

Rotate VD2 with crank handle to reface the valve seat in centerline with the valve guide under the correct seat angle.

If required, the refaced valve seat can be narrowed by using the side cutting edges of the cutting tool to machine the upper and lower edges of the valve seat.

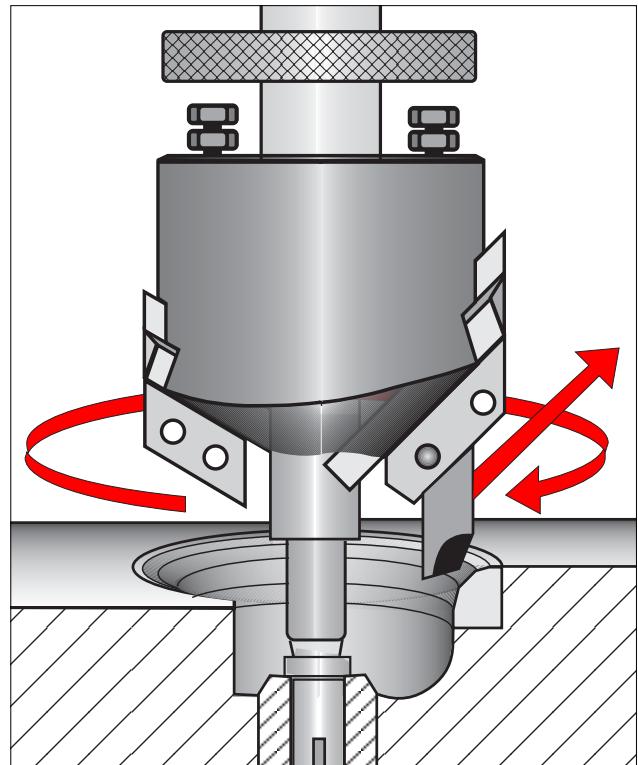

### Benefits:

No setting gauges, no time consuming measurements or guesswork

Lathe-type refacing removes material from the hardened and burned spots of the seat gradually from the side and, therefore, no upward spring action resulting in chatter marks will occur.

The refaced valve seat has a flawless concentric texture for a complete valve seal.

Because the depth of cut is preset by a micrometer downfeed mechanism, even an unexperienced operator is able to maintain positive control over the material being removed from the valve seat.

Roundness, concentricity and surface finish of the refaced seat are within manufacturers' specifications or even better.

Carbide-tipped cutting tools and cutting tools including a replaceable cutting insert are available.

# The Components of the VD2

## 1. VD2 Valve Seat Refacing Tool

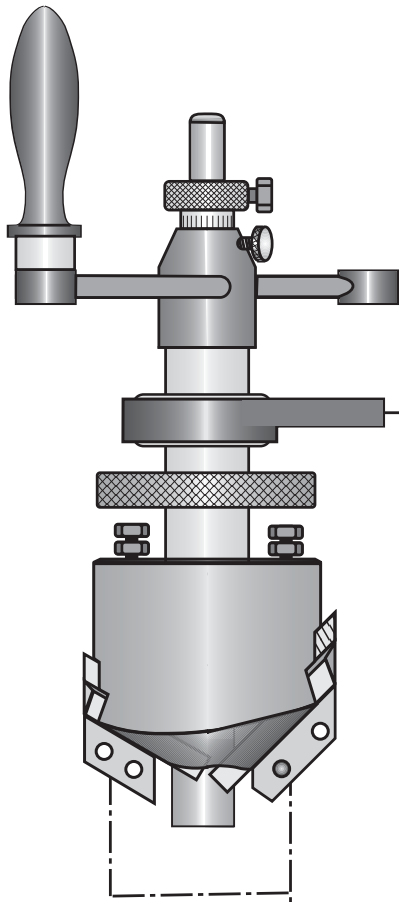

## 4. Steady

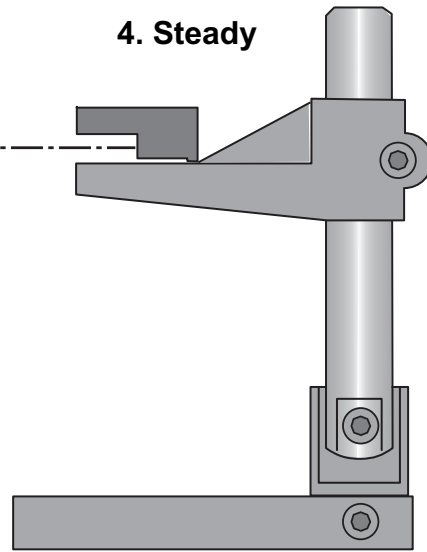

## 2. Pilots



## 3. Cutting tools

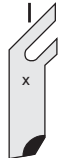

## 5. Service tools

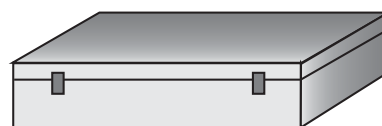
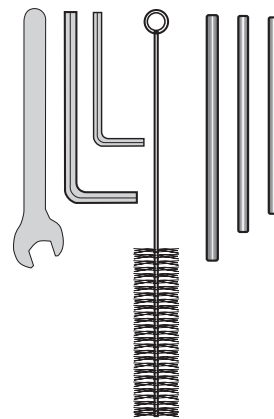

## 6. Storage case

## Pilots and Cutting Tools

The available pilots and the available cutting tools are listed in our Catalog "Tools and Equipment for Automotive Workshops".

The Catalog can be downloaded as pdf file from our website "www.ludwig-hunger.de".

### VD2 Kits

VD2 Kits are available to match the various requirements.

Each kit contains all the items needed in a storage case.

The storage case has space for additional pilots and cutters so that the kit can be updated, if new or additional engines are to be serviced.

Hunger uses information supplied by various sources to keep the contents of the kits up to date.

As specifications are liable to change without prior notice Hunger cannot be held responsible for inaccuracies which may occur from time to time.

In addition to the kits listed below Hunger supplies also kits as specified by the customer.

### Universal VD2 Kit

Description	Seat Angle	Part No.
VD2 Universal Kit	20°, 30° & 45°	217 03 100

### Special VD2 Kits

Description	Seat Angle	Part No.
VD2 Kit DAF Trucks	30° & 45°	217 03 107
VD2 Kit Ford Trucks	30° & 45°	217 03 126
VD2 Kit MAN	30° & 45°	217 03 105
VD2 Kit Ford Trucks	30° & 45°	217 03 126
VD2 Kit MTU 331/396	30° & 45°	217 03 130
VD2 Kit MTU 362	30° & 45°	217 03 131
VD2 Kit MTU 493	30° & 45°	217 03 132
VD2 Kit MTU 538	30° & 45°	217 03 133
VD2 Kit MTU 595	30° & 45°	217 03 138
VD2 Kit MTU 652	30° & 45°	217 03 134
VD2 Kit MTU 672	30° & 45°	217 03 135
VD2 Kit MTU 866/837	30° & 45°	217 03 136
VD2 Kit MTU 956	30° & 45°	217 03 137
VD2 Kit MTU 956-02	30° & 45°	217 03 148

### Ludwig Hunger GmbH

Graefelfinger Str. 146  
81375 Munich/Germany

Tel.: +49 89 7091-0  
Fax: +49 89 7091-26

info@ludwig-hunger.de  
www.ludwig-hunger.de